

Solray Modular Trident

Plan View

Data Sheet 5-2

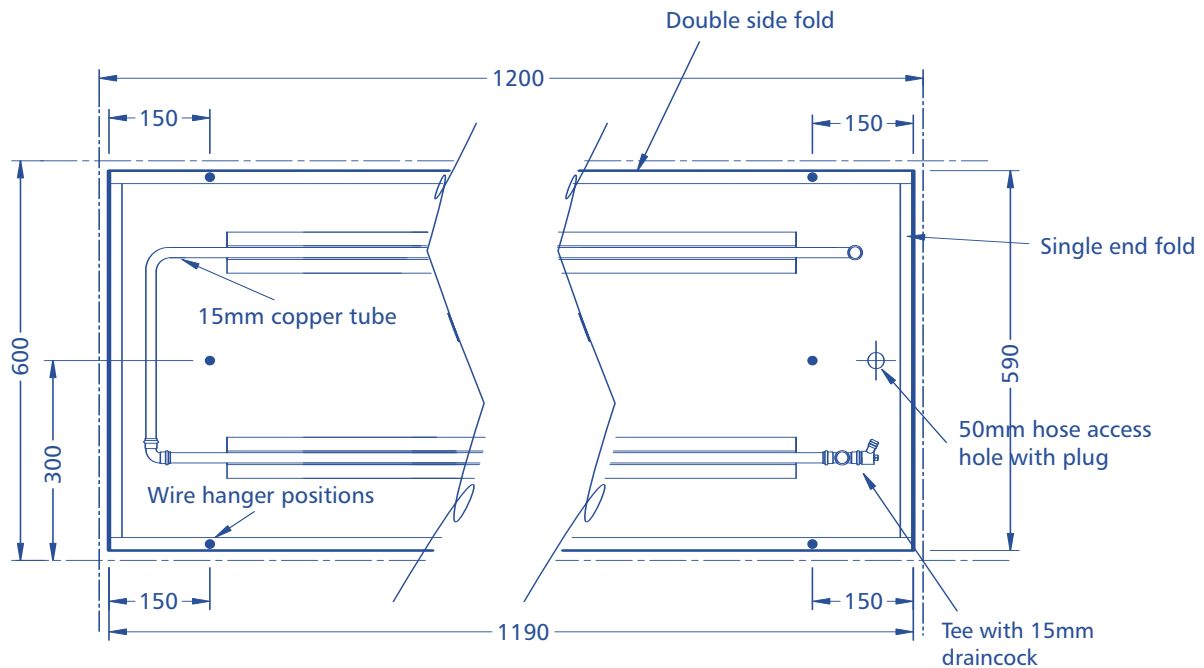

Standard Connection Detail

NOTES

All panels are constructed from 1.6mm or 16SWG thick aluminium sheet.

The panels are sized in set modules to fit into a 600mm ceiling tile grid pattern.

All panels are 590mm wide, with five modular lengths available – 590mm, 1190mm, 1790mm, 2390mm and 2990mm.

All panels have a 60mm fold with 20mm pretuned folds at the sides.

Two aluminium extrusions are fitted to the rear of the panel with spring clips to hold the copper tubes in place.

All panels are fitted with 50mm foil-back insulation and pressure tested to 7 bar.

Panels are painted RAL 9010 as standard.

All panels are supplied with adjustable eyebolts and wireclips to support the panel and drain plug disks fitted to the face as standard.